

CD/DVD Digital Printing Specifications

*Keylines (black circles) should not appear on final artwork/film, as they are not in the print area.

Do not use as template

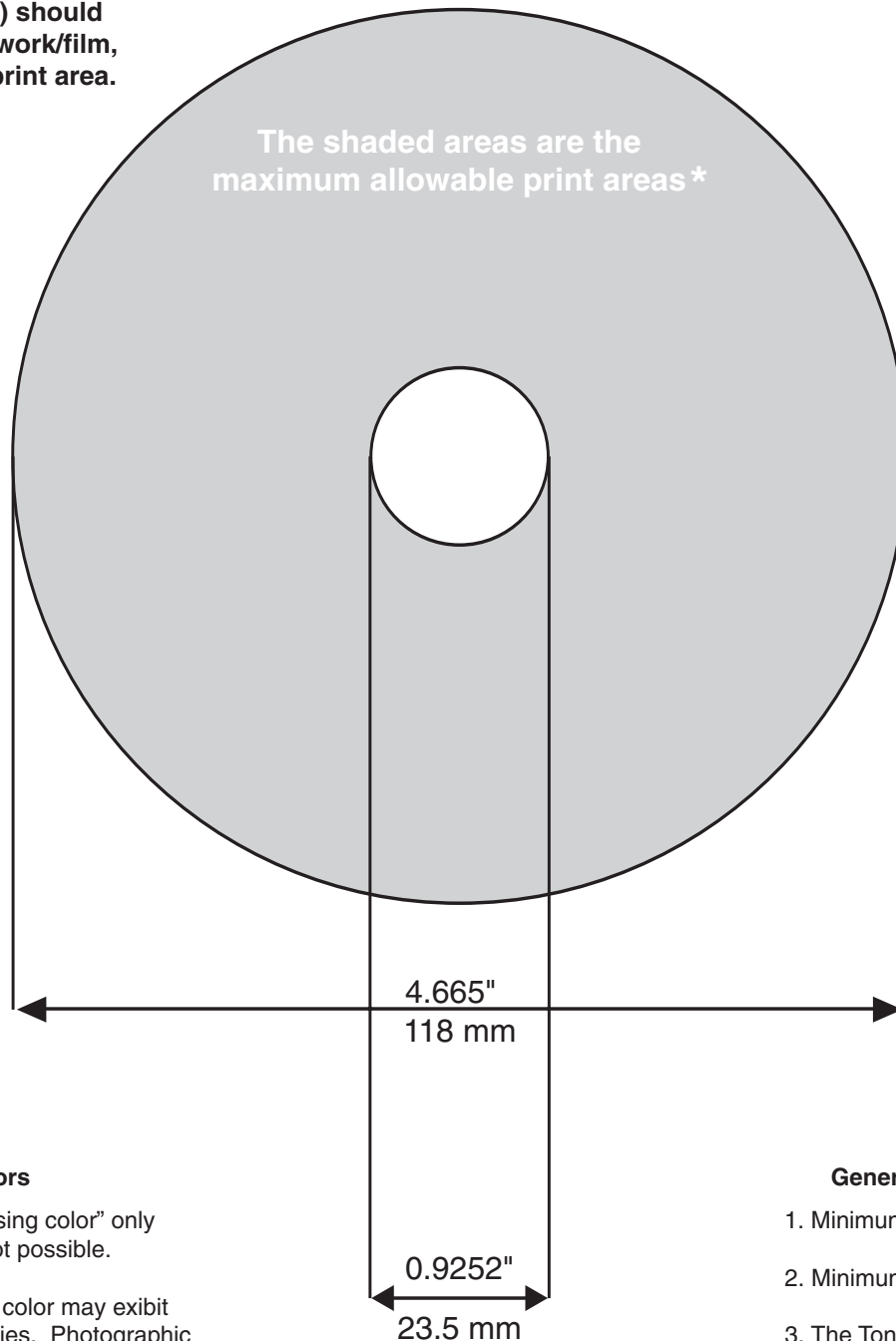

Digital Ink colors

1. Digital color is "pleasing color" only
Color matching is not possible.
2. Large areas of solid color may exhibit some uneven densities. Photographic images work best.
3. Digital printing requires a white background (no large areas of silver showing)

General Printing Specs

1. Minimum line width is 1/2 pt.
2. Minimum letter size is 6 pt. bold
3. The Tonal range for best results is 10% to 90%. While we will hold some of the dot outside these ranges, you may end up with some dot gain/loss.
4. Some gradients do not print well with silkscreening. Uneven blotchyness and or banding may occur. Before using gradients please consult with the DSGI art staff to insure the best possible results.

Design Specifications

Providing Art to DSGI

- All graphic design work is performed on Apple Power Macintosh Computers.
- We support the following software only:
Adobe Illustrator CS2, Macromedia Freehand 10.0, Quark Express 6.5, Adobe InDesign CS2, Adobe Photoshop CS2, and Adobe Pagemaker 6.5
- We accept Zip 100, and Jaz 1GB, as well as 3.5" floppy disks and CD or DVD media.
- To submit your art electronically please visit upload.dsgi.com and fill out the submission form.
- All fonts, for both screen and printer, and all linked images, must be included with your files. We suggest you use only Adobe Type 1 and compatible fonts. We cannot guarantee the results of a project using True Type fonts since most imagesetters cannot process True Type fonts.
- All scanned color images should be saved as CMYK TIFFs 300 DPI. If you provide us with RGB images, be aware that as we convert them into the necessary CMYK format, some color shifting will occur. Extra charges may apply if we need to convert RGB images to CMYK format.
- Scanned grayscale and line art images should be saved as 300 DPI TIFFs.
- **Black and white laser separations and a color proof of your project *MUST BE INCLUDED* with art supplied on disc**
- **A pdf representation of your file *MUST BE INCLUDED* with art supplied electronically**

Important

Do not send JPG, GIF, or any other type of compressed web ready art.

Do not send electronic art that has been pre-separated (i.e. a separate file for Cyan and Black plates).

Do not send art created in a program which is not listed above.

Artwork that is not provided in the recommended format or program may delay your job. Additional charges may apply if Diversified personnel are required to modify your artwork.

Graphics Checklist

THIS GRAPHICS CHECKLIST MUST BE COMPLETED AND RETURNED WITH YOUR GRAPHICS. AN INCOMPLETE CHECKLIST MAY ADD ADDITIONAL COST AND DELAY TO YOUR PROJECT. IF THERE IS ANYTHING YOU DO NOT UNDERSTAND OR FEEL DOES NOT PERTAIN TO YOUR PROJECT PLEASE DO NOT HESITATE TO CALL YOUR DIVERSIFIED SYSTEMS SALES REPRESENTATIVE AT (425) 947-1500 OR (800) 255-3142.

Customer Name: _____ Project Name: _____

Contact: _____ Sales Representative _____

Phone: _____ Fax: _____ e-mail: _____

Designer: _____ Phone: _____ e-mail: _____

Program which artwork has been submitted in: _____

Action . . .

Confirmed!

- Are your disks clearly labeled?
- Did you supply the artwork in the correct dimensions?
- Have you backed up the files you've submitted? (*DSGI is not responsible for maintaining your artwork*)
- Does your design denote PMS colors if applicable for the disc screen print?
- Did you leave your layers intact with any templates removeable?
- Did you save your color images as TIFF/CMYK? (for pixel based art)
- Have you supplied all native and imported files on your disk in a folder called "Source Files"?
- Have you supplied all screen and printer fonts relating to your project in a folder called " Fonts"?
- Did you include bleed (1/8") where appropriate? (paper printing only)
- Did you keep your text within 1/8" of your live image? (paper printing only)
- Did you make sure your artwork/photos are 300 DPI? (higher is not necessary)
- If you incorporated crop marks and registration marks, are they colored as "registration"?
- Did you delete all blank pages from your final files?
- Did you include a color composite of your files?
- Did you include laser separations of your files?

NOTES: _____

We (the customer) have indicated all information needed to process and complete the project above. Subsequent to the \$25 disk review, if additional time is needed to correct items not checked by the customer, that time will be billed at \$80.00 per hour (\$40.00 minimum repair charge).

Customer's Signature: X _____ Date submitted: _____